

THANK YOU FOR SELECTING A HUSKY FLOOR LINER FROM WINFIELD CONSUMER PRODUCTS

CARE AND USE INSTRUCTIONS

Your new floor liners are custom molded to fit your particular vehicle. The liners are made to take the place of your factory floor mats. For correct fit, it is necessary to remove the factory floor mats before installing your new floor liners. *However, do not remove the factory-installed carpeting.*

Your liners are made from an engineering resin that is lightweight and extremely tough and durable. The easiest way to clean your liners is with a damp cloth or sponge. If using a cleaner, 409® or Glass Plus® work well. Use of Armor All®, Son-of-a-Gun® or similar items is discouraged as these products make the liners slick.

INSTALLATION INSTRUCTIONS FOR YOUR CHEVROLET TAHOE GMC YUKON & YUKON DENALI SECOND SEAT FLOOR LINERS

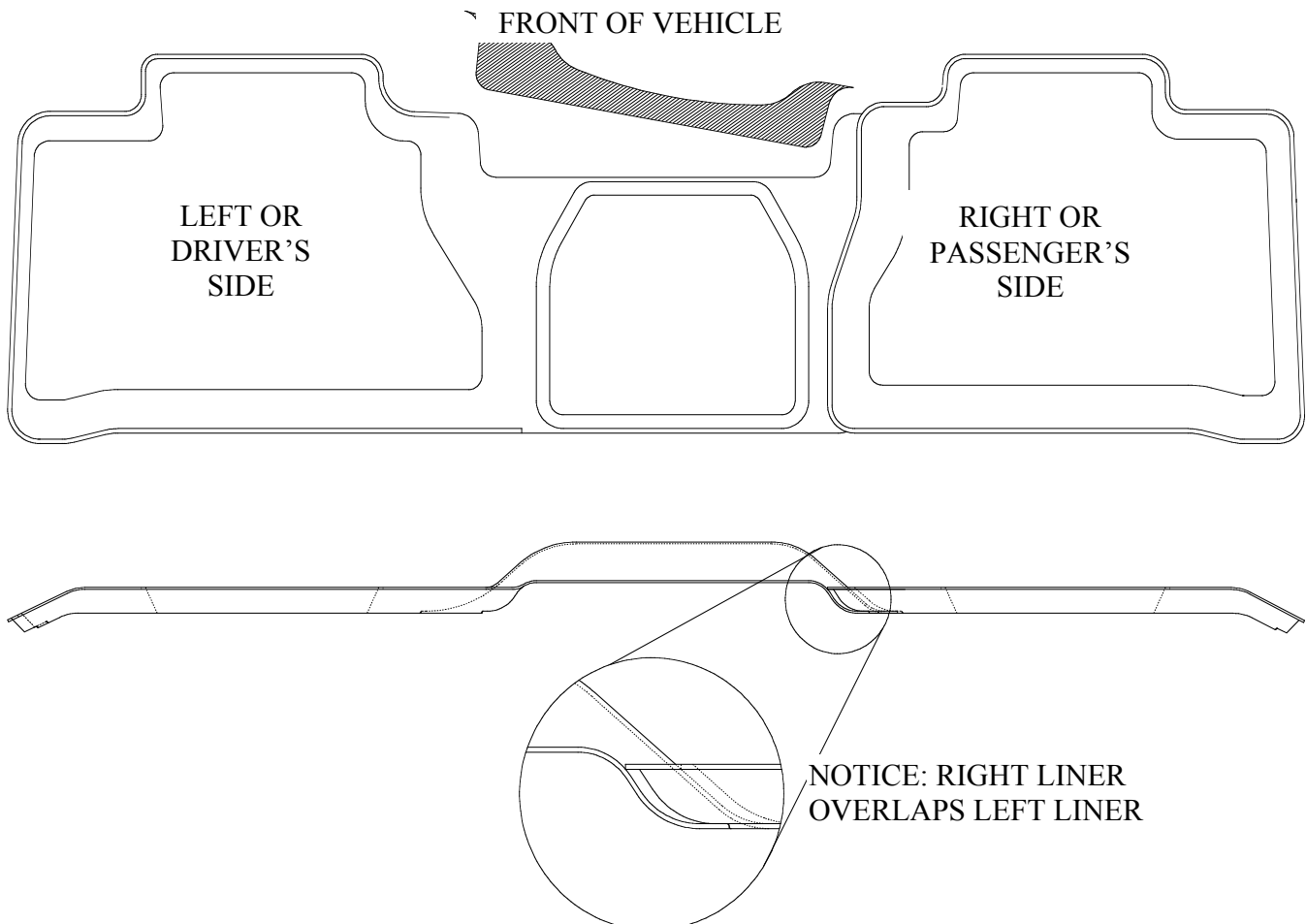

IF YOUR VEHICLE IS EQUIPPED WITH THE OPTIONAL 40/20/40 SPLIT BENCH FRONT ROW SEAT, YOUR LINER WILL NEED TO BE TRIMMED BEFORE IT WILL FIT PROPERLY. TO TRIM, SIMPLY REMOVE THE MATERIAL ON THE CENTER HUMP PORTION OF THE LINER WHERE IT MATES UP TO PULL OUT CUP HOLDER AS SHOWN IN THE DIAGRAM ABOVE (SEE PHOTO OF TRIMMED PART ON BACK). A GROOVE IS MOLDED INTO THE LINER TO GUIDE TRIMMING. A UTILITY KNIFE OR HEAVY SHEARS WORK WELL FOR TRIMMING.

PHOTOS OF PART #6142 TRIMMED FOR THE CHEVROLET TAHOE/GMC YUKON

