

THANK YOU FOR SELECTING A HUSKY FLOOR LINER FROM WINFIELD CONSUMER PRODUCTS

CARE AND USE INSTRUCTIONS

Your new floor liners are custom molded to fit your particular vehicle. The liners are made to take the place of your factory floor mats. For correct fit, it is necessary to remove the factory floor mats before installing your new floor liners. *However, do not remove the factory-installed carpeting.*

Your liners are made from an engineering resin that is lightweight and extremely tough and durable. The easiest way to clean your liners is with a damp cloth or sponge. If using a cleaner, 409® or Glass Plus® work well. Use of Armor All®, Son-of-a-Gun® or similar items is discouraged as these products make the liners slick.

INSTALLATION INSTRUCTIONS FOR YOUR CHEVROLET TAHOE/ GMC YUKON/CADILLAC ESCALADE SECOND SEAT FLOOR LINERS

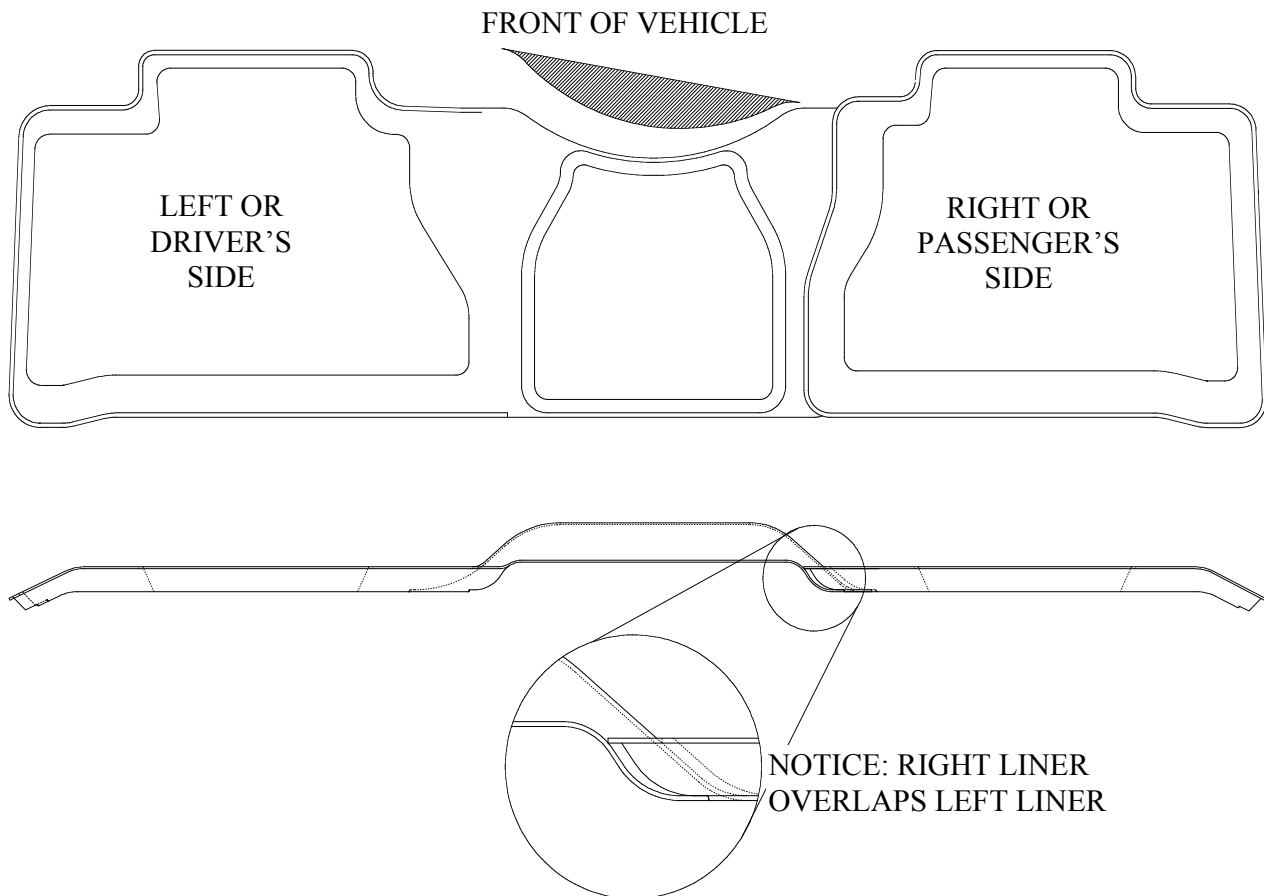

IF YOUR VEHICLE IS EQUIPPED WITH THE OPTIONAL FRONT BUCKET SEATS AND CENTER CONSOLE, YOU WILL NEED TO TRIM YOUR LINER TO ACHIEVE THE PROPER FIT ALONG THE BACK EDGE OF THE CONSOLE. TO ADJUST FIT, SIMPLY TRIM AWAY THE MATERIAL ON THE CENTER HUMP PORTION OF THE LINER THAT MATES UP TO THE CENTER CONSOLE (SEE DARKENED AREA IN DRAWING ABOVE). A TRIM GROOVE IS MOLDED INTO THE LINER TO GUIDE TRIMMING. A UTILITY KNIFE OR HEAVY SHEARS WORK WELL FOR TRIMMING. PHOTOS OF THE TRIMMED PART ARE SHOWN ON THE BACK OF THIS PAGE.

PHOTOS OF PART #6141 TRIMMED FOR THE CHEVROLET TAHOE/GMC
YUKON/CADILLAC ESCALDE

