

THANK YOU FOR SELECTING A HUSKY FLOOR LINER FROM WINFIELD CONSUMER PRODUCTS

CARE AND USE INSTRUCTIONS

Your new floor liners are custom molded to fit your particular vehicle. The liners are made to take the place of your factory floor mats. For correct fit, it is necessary to remove the factory floor mats before installing your new floor liners. *However, do not remove the factory-installed carpeting.*

Your liners are made from an engineering resin that is lightweight and extremely tough and durable. The easiest way to clean your liners is with a damp cloth or sponge. If using a cleaner, 409® or Glass Plus® work well. Use of Armor All®, Son-of-a-Gun® or similar items is discouraged as these products make the liners slick.

INSTALLATION INSTRUCTIONS FOR YOUR DODGE DAKOTA CLUB CAB SECOND SEAT FLOOR LINERS

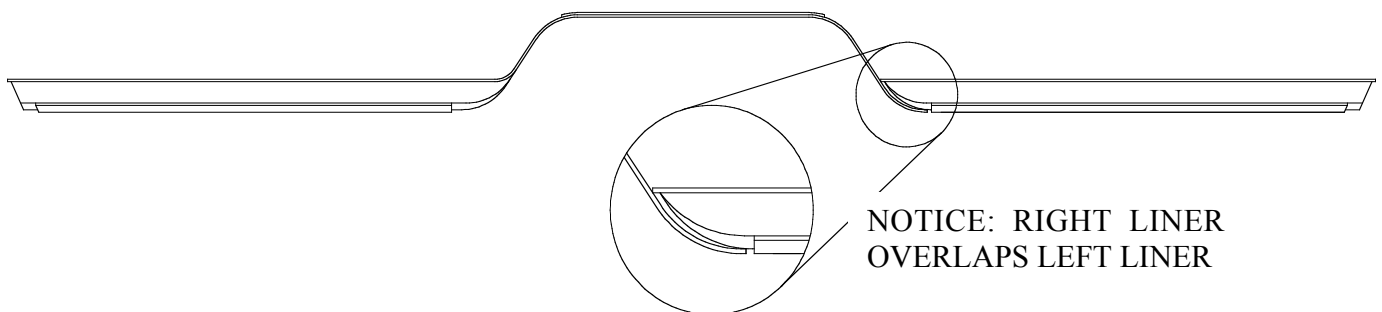
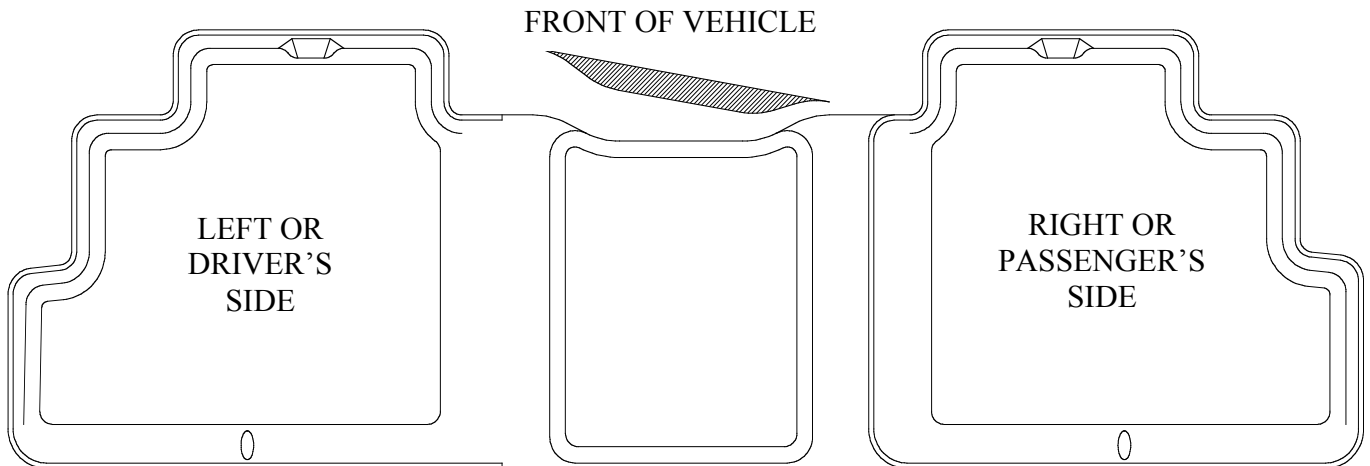

TO EASE INSTALLATION OF YOUR SECOND SEAT LINERS, POSITION BOTH FRONT SEATS TO THEIR MOST FORWARD POSITION BEFORE INSTALLING. ONCE LINERS ARE INSTALLED, REPOSITION SEATS AS NEEDED. NOTE THAT CUSTOMERS WITH THE FACTORY CENTER CONSOLE WILL NEED TO TRIM THEIR DRIVER'S SIDE LINER TO ACHIEVE THE PROPER FIT. BEFORE TRIMMING, FIRST TEST FIT THE LINERS TO DETERMINE IF TRIMMING NEEDED. IF TRIMMING IS NECESSARY, USE A UTILITY KNIFE OR HEAVY SHEARS AND FOLLOW THE MOLDED IN TRIM GROOVE TO REMOVE THE TRIM AREA LOCATED ON THE CENTER HUMP COVER PORTION OF THE DRIVER'S SIDE LINER (SEE DRAWING ABOVE).