

### 99-01 FORD EXCURSION LIMITED REAR MUD GUARD INSTALLATION INSTRUCTIONS

*Please read instructions thoroughly before installation.*

#### Tools Required

- 1/8" drill bit / Drill
- Short #2 Phillips screwdriver
- Center punch

#### Package Contents

- Driver & passenger side rear mud guard
- #10 screw (qty. 8)
- U-Clip (qty. 2)
- Instruction sheet

**NOTE:** It may be necessary to remove the rear wheels for mud guard installation.

1. Clean and degrease the mud guard location area on the fender before installation.
  2. Remove factory fastener from locations A and B (Figure 1).
  3. Attach mud guard to rear fender with the factory fastener at location B, check fit and alignment. Adjust accordingly before tightening.
  4. Using the mud guard as a template, center punch and drill an 1/8" hole at location C and D (Figure 1).
  5. Install a #10 screw at location C and D.
  6. Install #10 screw at location A through the mud guard and fender and into a U-Clip (Figure 1 and 2).
- NOTE: The U-Clip is used as a nut for the #10 screw and does not clip over the fender or liner panel.

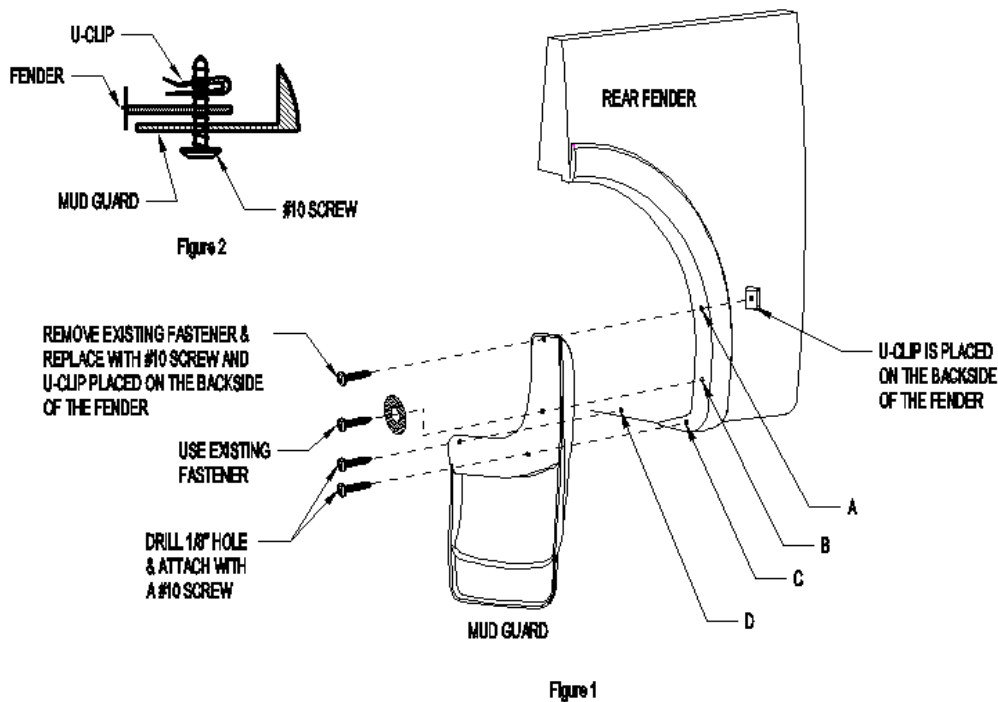

#### **PAINTING INSTRUCTIONS**

1. Clean mud guard with a soap and water solution to remove dirt and other contaminants.
2. Sand painting surface with 320 grit sand paper.
3. Apply a coating of flexible primer-adhesion promoter.
4. Apply a flexible paint as directed by the paint manufacturer.