

99-01 FORD EXCURSION LIMITED FRONT MUD GUARD INSTALLATION INSTRUCTIONS

Please read instructions thoroughly before installation.

Tools Required

- 1/8" drill bit / Drill
- Short #2 Phillips screwdriver
- Center punch

Package Contents

- Driver & passenger side rear mud guard
- #10 screw (qty. 8)
- Instruction sheet

NOTE: Turn the front wheels all the way to the left or right for mud guard installation. However, it may be necessary to remove the wheels depending on the tools being used for installation.

1. Clean and degrease the mud guard location area on the fender before installation.
2. Remove factory fastener from locations B (Figure 1).
3. Attach mud guard to front fender with the factory fastener at location B, check fit and alignment. Adjust accordingly.
4. Using the mud guard as a template, center punch and drill an 1/8" hole at location A, C and D (Figure 1).
5. Install a #10 screw at location A, C and D.

NOTE: DO NOT USE SMALL HOLES FOR FASTENING (Figure 1).

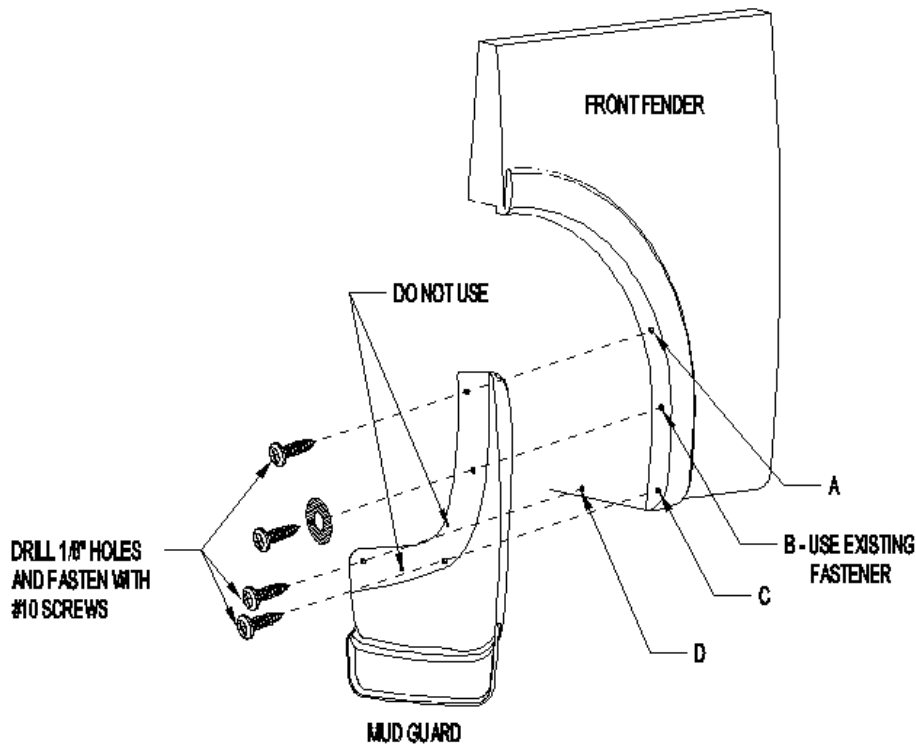

Figure 1

PAINTING INSTRUCTIONS

1. Clean mud guard with a soap and water solution to remove dirt and other contaminants.
2. Sand painting surface with 320 grit sand paper.
3. Apply a coating of flexible primer-adhesion promoter.
4. Apply a flexible paint as directed by the paint manufacturer.