

## 97-02 FORD F-150 FRONT MUD GUARD INSTALLATION INSTRUCTIONS

*Install Paint Protection Film before mud guards (see other side)  
Please read instructions thoroughly before installation.*

### Tools Required:

- 1/8" drill bit / Drill
- Short Phillips screwdriver
- Center punch

### Package Contents

- Driver & passenger side mud guard
- #10 screw (qty. 8)
- Paint Protection Film (1 set)
- Instruction sheet

**NOTE:** Turn the front wheels all the way to the left or right for mud guard installation. However, it may be necessary to remove the wheels depending on the tools being used for installation.

1. Clean and degrease the mud guard location area on the fender before installation.
2. Remove factory fasteners from location B and C (see below).
3. Attach mud guard to front fender with the factory fasteners at location B and C, check fit and alignment. Adjust accordingly before tightening.
4. Using the mud guard as a template, center punch, drill 1/8" hole, and install #10 screws at locations A and D into fender
5. Drill 1/8" hole and install #10 screws at location E and F into the fender liner.

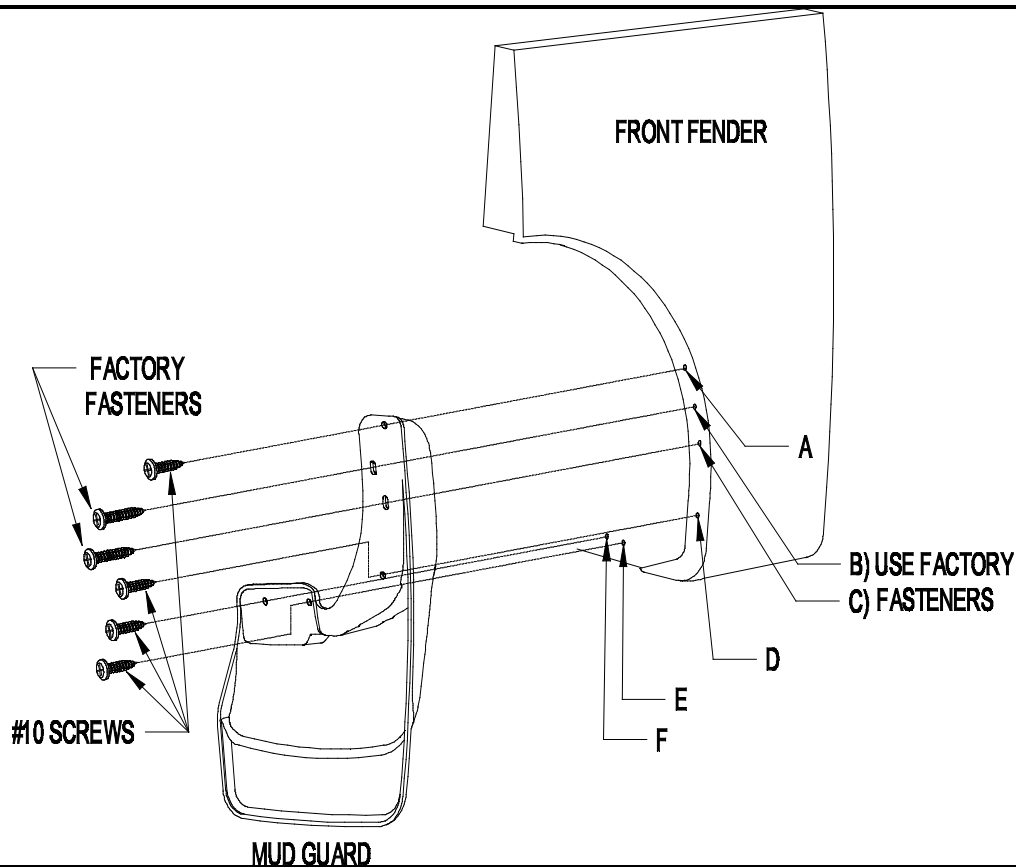

### **PAINTING INSTRUCTIONS**

1. Clean mud guard with a soap and water solution to remove dirt and other contaminants.
2. Sand painting surface with 320 grit sand paper.
3. Apply a coating of flexible primer-adhesion promoter.
4. Apply a flexible paint as directed by the paint manufacturer.

### PAINT PROTECTION FILM - INSTALLATION INSTRUCTIONS

**NOTE:** *The Paint Protection Film is a precut template of film used to protect the mud guard mounting surfaces of your fenders against wear. The templates (left and right side) can be removed from the backing liner by folding the liner at the center cut of the template, separating the film sides and peeling the film templates from the backing liner.*

1. Position mud guard on fender to indicate placement location of paint protection film.
2. Clean the placement area of fender with a clean cotton cloth and a petroleum distillate based cleaner such as DuPonts Prep-Sol Brand Solvent Cleaner or 3M Brand Adhesive Cleaner and dry.
3. Mix a wetting solution of 1 pint of water with 4 drops of liquid dishwashing detergent.
4. Mark correct position of film by placing mud guard against fender.
5. Remove protection film from liner and flood adhesive side of film with wetting solution (use a spray bottle or sponge).
6. Thoroughly wet film placement location of fender with wetting solution.
7. Position the adhesive side of film on fender and flood with wetting solution.
8. Check location of film with mud guard and reposition as necessary.
9. Using a sponge, squeegee any air bubbles and wrinkles from film.
10. Allow film to dry before installing mud guard.

